**SEMITOP® 3**

## IGBT Module

**SK10GD126ET**

Preliminary Data

### Features

- Compact design
- One screw mounting
- Heat transfer and isolation through direct copper bonded aluminium oxide ceramic (DCB)
- Ultrafast NPT technology IGBT
- CAL technology FWD
- Integrated NTC temperature sensor

### Typical Applications\*

- Inverter

Absolute Maximum Ratings		$T_s = 25\text{ }^\circ\text{C}$ , unless otherwise specified		
Symbol	Conditions	Values		Units
<b>IGBT</b>				
$V_{CES}$	$T_j = 25\text{ }^\circ\text{C}$	1200		V
$I_C$	$T_j = 150\text{ }^\circ\text{C}$	$T_s = 25\text{ }^\circ\text{C}$	15	A
		$T_s = 80\text{ }^\circ\text{C}$	11	A
$I_{CRM}$	$I_{CRM} = 2 \times I_{Cnom}$	16		A
$V_{GES}$		± 20		V
$t_{psc}$	$V_{CC} = 600\text{ V}; V_{GE} \leq 20\text{ V}; T_j = 125\text{ }^\circ\text{C}$ $V_{CES} < 1200\text{ V}$	10		µs
<b>Inverse Diode</b>				
$I_F$	$T_j = 150\text{ }^\circ\text{C}$	$T_s = 25\text{ }^\circ\text{C}$	25	A
		$T_s = 80\text{ }^\circ\text{C}$	17	A
$I_{FRM}$	$I_{FRM} = 2 \times I_{Fnom}$	30		A
<b>Module</b>				
$I_{t(RMS)}$				A
$T_{vj}$		-40 ... +150		°C
$T_{stg}$		-40 ... +125		°C
$V_{isol}$	AC, 1 min.	2500		V

Characteristics		$T_s = 25\text{ }^\circ\text{C}$ , unless otherwise specified			
Symbol	Conditions	min.	typ.	max.	Units
<b>IGBT</b>					
$V_{GE(th)}$	$V_{GE} = V_{CE}, I_C = 0,3\text{ mA}$	5	5,8	6,5	V
$I_{CES}$	$V_{GE} = 0\text{ V}, V_{CE} = V_{CES}$	$T_j = 25\text{ }^\circ\text{C}$	0,05		mA
		$T_j = 125\text{ }^\circ\text{C}$			mA
$I_{GES}$	$V_{CE} = 0\text{ V}, V_{GE} = 20\text{ V}$	$T_j = 25\text{ }^\circ\text{C}$	120		nA
		$T_j = 125\text{ }^\circ\text{C}$			nA
$V_{CE0}$		$T_j = 25\text{ }^\circ\text{C}$	1	1,2	V
		$T_j = 125\text{ }^\circ\text{C}$	0,9		V
$r_{CE}$	$V_{GE} = 15\text{ V}$	$T_j = 25\text{ }^\circ\text{C}$	87	113	mΩ
		$T_j = 125\text{ }^\circ\text{C}$	138		mΩ
$V_{CE(sat)}$	$I_{Cnom} = 8\text{ A}, V_{GE} = 15\text{ V}$	$T_j = 25\text{ }^\circ\text{C}_{chiplev.}$	1,7	2,1	V
		$T_j = 125\text{ }^\circ\text{C}_{chiplev.}$	2,2		V
$C_{ies}$	$V_{CE} = 25, V_{GE} = 0\text{ V}$	$f = 1\text{ MHz}$	0,6		nF
$C_{oes}$			0,037		nF
$C_{res}$			0,029		nF
$t_{d(on)}$	$R_{Gon} = 75\text{ }^\circ\Omega$	$V_{CC} = 600\text{ V}$ $I_C = 8\text{ A}$	85		ns
$t_r$			30		ns
$E_{on}$			1		mJ
$t_{d(off)}$	$R_{Goff} = 75\text{ }^\circ\Omega$	$T_j = 125\text{ }^\circ\text{C}$ $V_{GE} = \pm 15\text{ V}$	430		ns
$t_f$			90		ns
$E_{off}$			1		mJ
$R_{th(j-s)}$	per IGBT			2	K/W

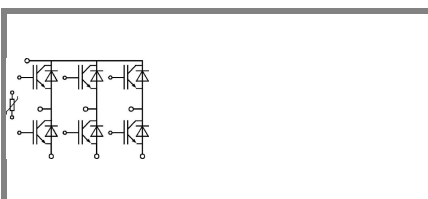
**GD-ET**

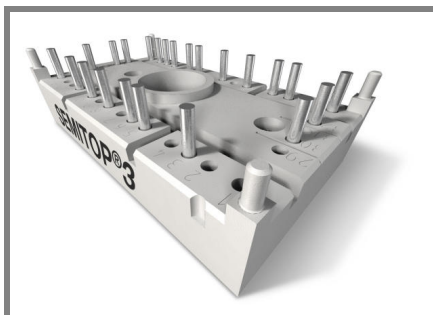

**SEMITOP<sup>®</sup> 3**

## IGBT Module

**SK10GD126ET**

Preliminary Data

### Features

- Compact design
- One screw mounting
- Heat transfer and isolation through direct copper bonded aluminium oxide ceramic (DCB)
- Ultrafast NPT technology IGBT
- CAL technology FWD
- Integrated NTC temperature sensor

### Typical Applications\*

- Inverter

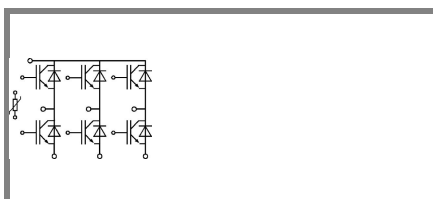

**GD-ET**

### Characteristics

Symbol	Conditions	min.	typ.	max.	Units	
<b>Inverse Diode</b>						
$V_F = V_{EC}$	$I_{Fnom} = 8 \text{ A}; V_{GE} = 0 \text{ V}$		$T_j = 25 \text{ }^\circ\text{C}_{\text{chiplev.}}$	1,9	2,2	V
			$T_j = 125 \text{ }^\circ\text{C}_{\text{chiplev.}}$	2		V
$V_{F0}$			$T_j = 25 \text{ }^\circ\text{C}$	1	1,1	V
			$T_j = 125 \text{ }^\circ\text{C}$	0,8	0,9	V
$r_F$			$T_j = 25 \text{ }^\circ\text{C}$	40	47	mΩ
			$T_j = 125 \text{ }^\circ\text{C}$	53		mΩ
$I_{RRM}$	$I_F = 15 \text{ A}$	$T_j = 125 \text{ }^\circ\text{C}$		21	A	
$Q_{rr}$	$di/dt = -300 \text{ A}/\mu\text{s}$			3,5	μC	
$E_{rr}$	$V_{CC} = 600\text{V}$			1,4	mJ	
$R_{th(j-s)D}$	per diode			2,1	K/W	
$M_s$	to heat sink	2,25		2,5	Nm	
w			30		g	
<b>Temperature sensor</b>						
$R_{100}$	$T_s = 100^\circ\text{C} (R_{25} = 5\text{k}\Omega)$		493±5%		Ω	

This is an electrostatic discharge sensitive device (ESDS), international standard IEC 60747-1, Chapter IX.

\* The specifications of our components may not be considered as an assurance of component characteristics. Components have to be tested for the respective application. Adjustments may be necessary. The use of SEMIKRON products in life support appliances and systems is subject to prior specification and written approval by SEMIKRON. We therefore strongly recommend prior consultation of our personal.

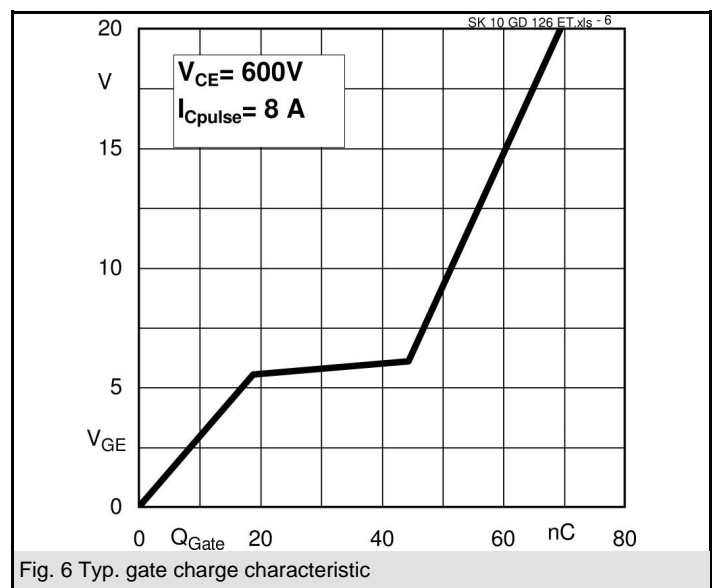
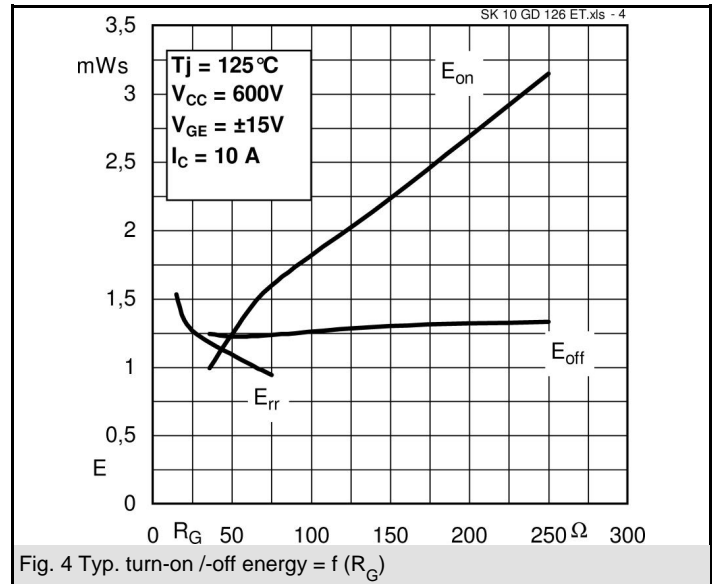
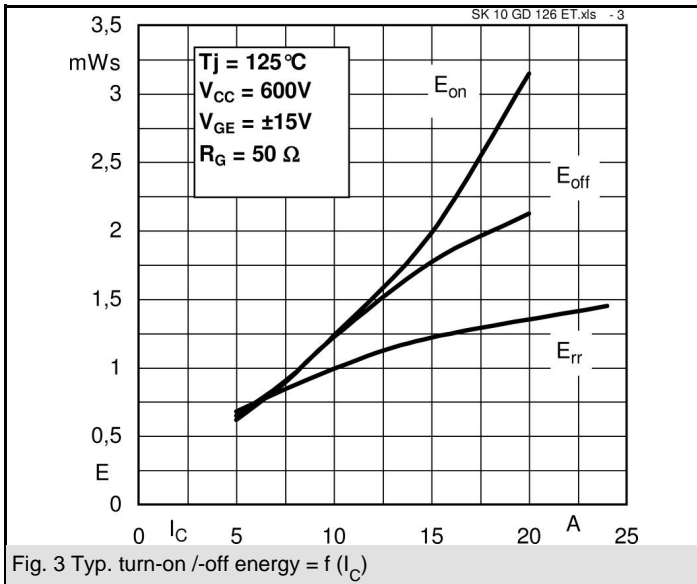
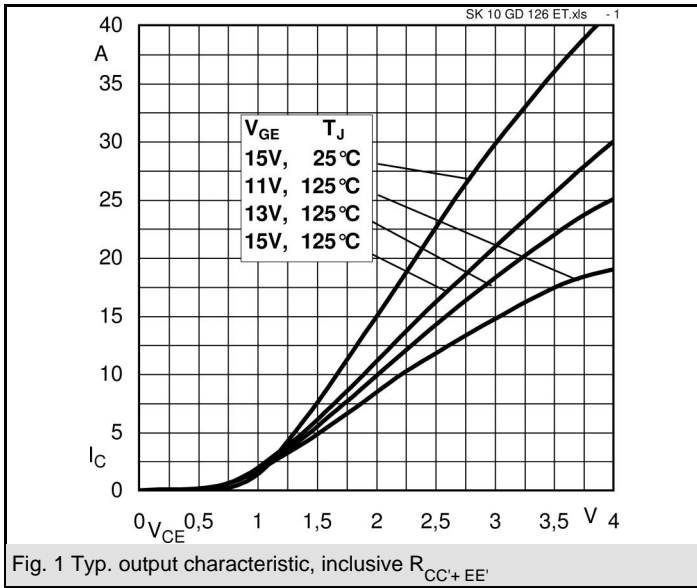

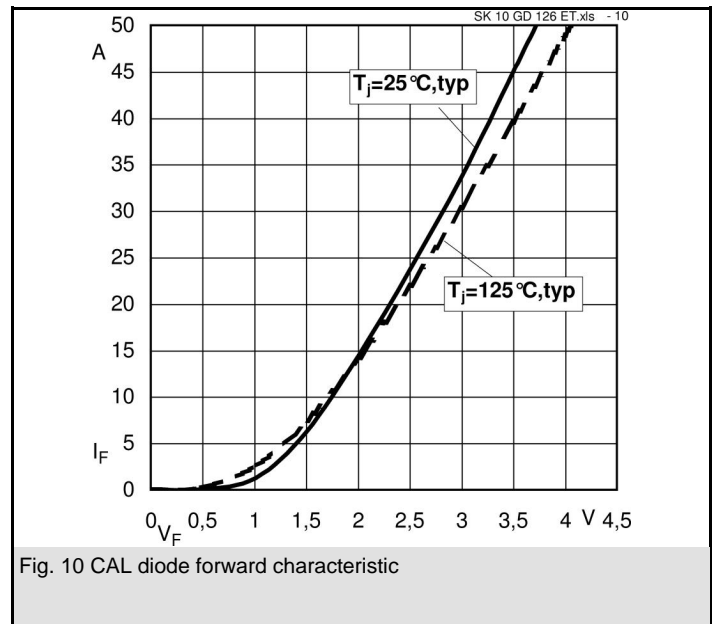
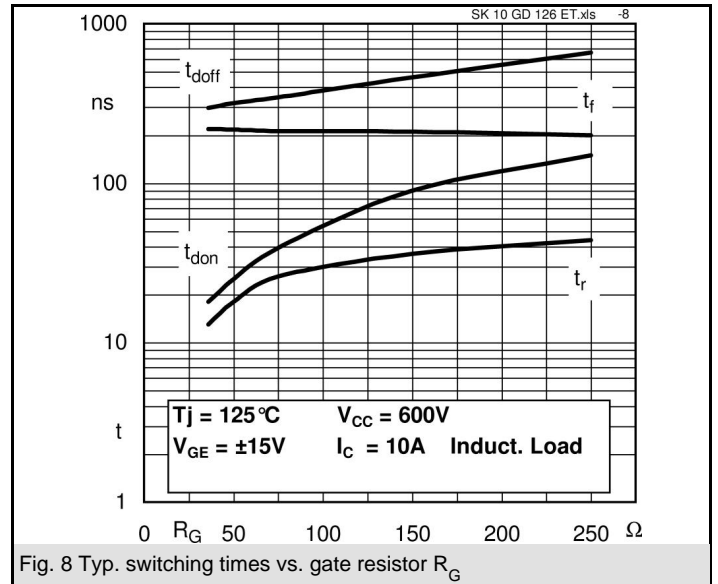
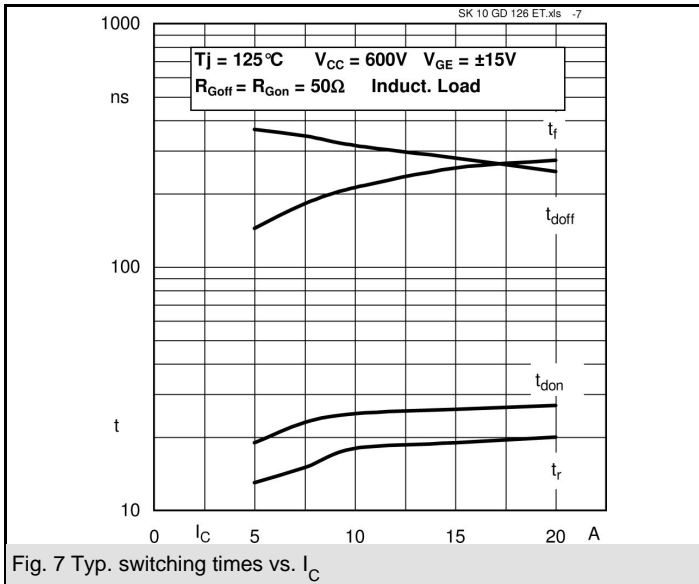

UL recognized file

no. E 63 532

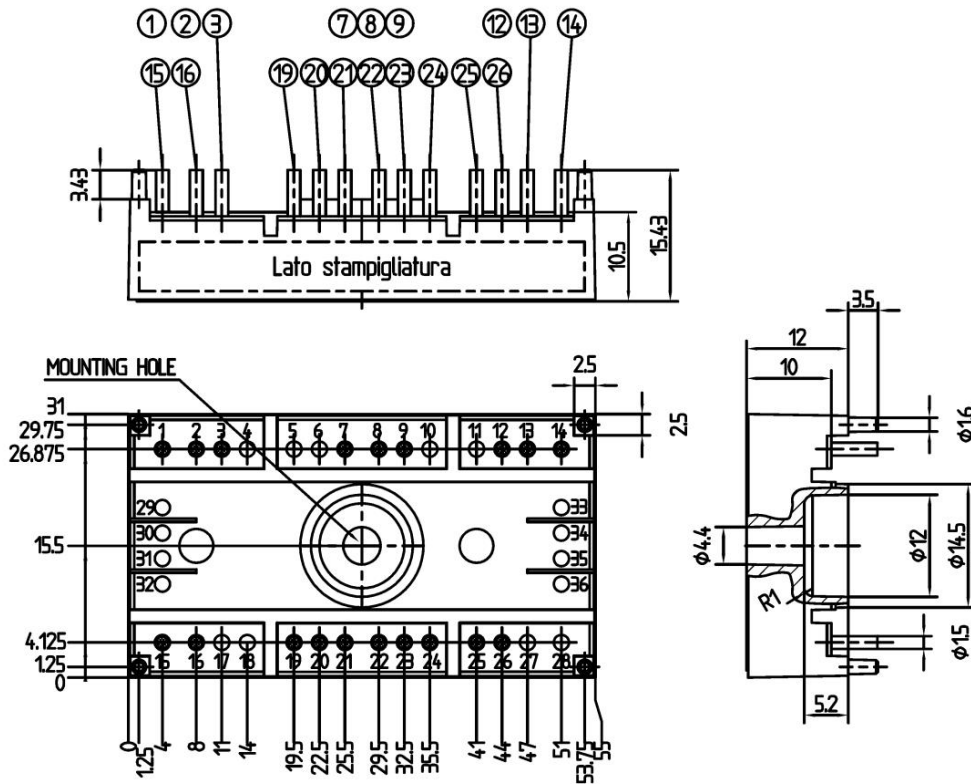

Case T52 (Suggested hole diameter, in the PCB, for solder pins and plastic mounting pins: 2mm)

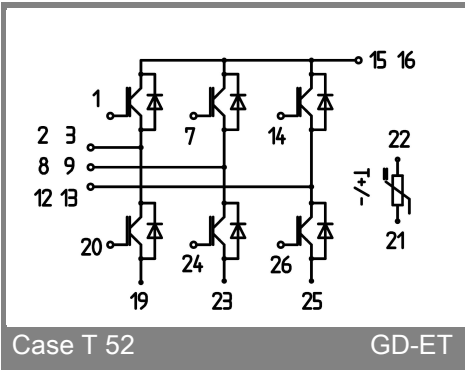

Case T 52

GD-ET