

SEMITOP[®] 3

IGBT Module

SK35GD126ET

Preliminary Data

Features

- Compact design
- One screw mounting
- Heat transfer and isolation through direct copper bonded aluminium oxide ceramic (DCB)
- Ultrafast NPT technology IGBT
- CAL technology FWD
- Integrated NTC temperature sensor

Typical Applications*

- Inverter

Absolute Maximum Ratings		$T_s = 25\text{ }^\circ\text{C}$, unless otherwise specified		
Symbol	Conditions	Values		Units
IGBT				
V_{CES}	$T_j = 25\text{ }^\circ\text{C}$	1200		V
I_C	$T_j = 150\text{ }^\circ\text{C}$	$T_s = 25\text{ }^\circ\text{C}$	40	A
		$T_s = 80\text{ }^\circ\text{C}$	32	A
I_{CRM}	$I_{CRM} = 2 \times I_{Cnom}$	70		A
V_{GES}		± 20		V
t_{psc}	$V_{CC} = 600\text{ V}; V_{GE} \leq 20\text{ V}; T_j = 125\text{ }^\circ\text{C}$ $V_{CES} < 1200\text{ V}$	10		μs
Inverse Diode				
I_F	$T_j = 150\text{ }^\circ\text{C}$	$T_s = 25\text{ }^\circ\text{C}$	34	A
		$T_s = 80\text{ }^\circ\text{C}$	23	A
I_{FRM}	$I_{FRM} = 2 \times I_{Fnom}$	70		A
Module				
$I_{t(RMS)}$				A
T_{vj}		-40 ... +150		$^\circ\text{C}$
T_{stg}		-40 ... +125		$^\circ\text{C}$
V_{isol}	AC, 1 min.	2500		V

Characteristics		$T_s = 25\text{ }^\circ\text{C}$, unless otherwise specified			
Symbol	Conditions	min.	typ.	max.	Units
IGBT					
$V_{GE(th)}$	$V_{GE} = V_{CE}, I_C = 1,5\text{ mA}$	5	5,8	6,5	V
I_{CES}	$V_{GE} = 0\text{ V}, V_{CE} = V_{CES}$	$T_j = 25\text{ }^\circ\text{C}$			mA
		$T_j = 125\text{ }^\circ\text{C}$			mA
I_{GES}	$V_{CE} = 0\text{ V}, V_{GE} = 20\text{ V}$	$T_j = 25\text{ }^\circ\text{C}$	600		nA
		$T_j = 125\text{ }^\circ\text{C}$			nA
V_{CE0}		$T_j = 25\text{ }^\circ\text{C}$	1	1,2	V
		$T_j = 125\text{ }^\circ\text{C}$	0,9		V
r_{CE}	$V_{GE} = 15\text{ V}$	$T_j = 25\text{ }^\circ\text{C}$	20	26	$\text{m}\Omega$
		$T_j = 125\text{ }^\circ\text{C}$	31		$\text{m}\Omega$
$V_{CE(sat)}$	$I_{Cnom} = 35\text{ A}, V_{GE} = 15\text{ V}$	$T_j = 25\text{ }^\circ\text{C}_{chiplev.}$	1,7	2,1	V
		$T_j = 125\text{ }^\circ\text{C}_{chiplev.}$	2		V
C_{ies}	$V_{CE} = 25, V_{GE} = 0\text{ V}$	$f = 1\text{ MHz}$	2,5		nF
C_{oes}			0,132		nF
C_{res}			0,115		nF
$t_{d(on)}$	$R_{Gon} = 15\text{ }\Omega$	$V_{CC} = 600\text{ V}$ $I_C = 35\text{ A}$	85		ns
t_r			30		ns
E_{on}			4,6		mJ
$t_{d(off)}$	$R_{Goff} = 15\text{ }\Omega$	$T_j = 125\text{ }^\circ\text{C}$ $V_{GE} = \pm 15\text{ V}$	430		ns
t_f			90		ns
E_{off}			4,3		mJ
$R_{th(j-s)}$	per IGBT			1,05	K/W

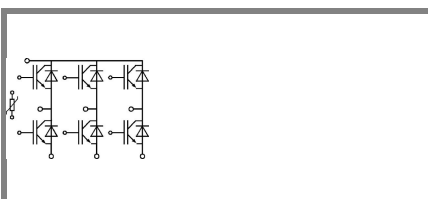

GD-ET

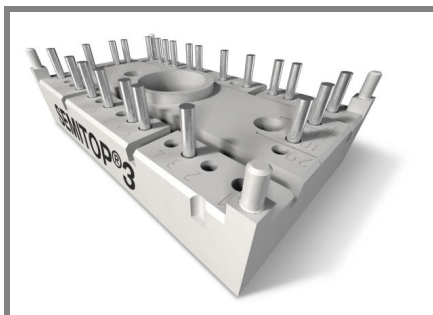

SEMITOP[®] 3

IGBT Module

SK35GD126ET

Preliminary Data

Features

- Compact design
- One screw mounting
- Heat transfer and isolation through direct copper bonded aluminium oxide ceramic (DCB)
- Ultrafast NPT technology IGBT
- CAL technology FWD
- Integrated NTC temperature sensor

Typical Applications*

- Inverter

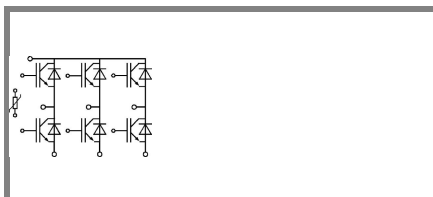

GD-ET

Characteristics

Symbol	Conditions	min.	typ.	max.	Units	
Inverse Diode						
$V_F = V_{EC}$	$I_{Fnom} = 35 \text{ A}; V_{GE} = 0 \text{ V}$		$T_j = 25 \text{ }^\circ\text{C}_{chiplev.}$	1,8	2,1	V
			$T_j = 125 \text{ }^\circ\text{C}_{chiplev.}$	1,8		V
V_{F0}			$T_j = 25 \text{ }^\circ\text{C}$	1	1,1	V
			$T_j = 125 \text{ }^\circ\text{C}$	0,8		V
r_F			$T_j = 25 \text{ }^\circ\text{C}$	23	29	mΩ
			$T_j = 125 \text{ }^\circ\text{C}$	31		mΩ
I_{RRM}	$I_F = 35 \text{ A}$	$T_j = 125 \text{ }^\circ\text{C}$	43		A	
Q_{rr}	$di/dt = -1330 \text{ A}/\mu\text{s}$		7		μC	
E_{rr}	$V_{CC} = 600\text{V}$		2,9		mJ	
$R_{th(j-s)D}$	per diode			1,7	K/W	
M_s	to heat sink	2,25		2,5	Nm	
w			30		g	
Temperature sensor						
R_{100}	$T_s = 100^\circ\text{C} (R_{25} = 5\text{k}\Omega)$		493±5%		Ω	

This is an electrostatic discharge sensitive device (ESDS), international standard IEC 60747-1, Chapter IX.

* The specifications of our components may not be considered as an assurance of component characteristics. Components have to be tested for the respective application. Adjustments may be necessary. The use of SEMIKRON products in life support appliances and systems is subject to prior specification and written approval by SEMIKRON. We therefore strongly recommend prior consultation of our personal.

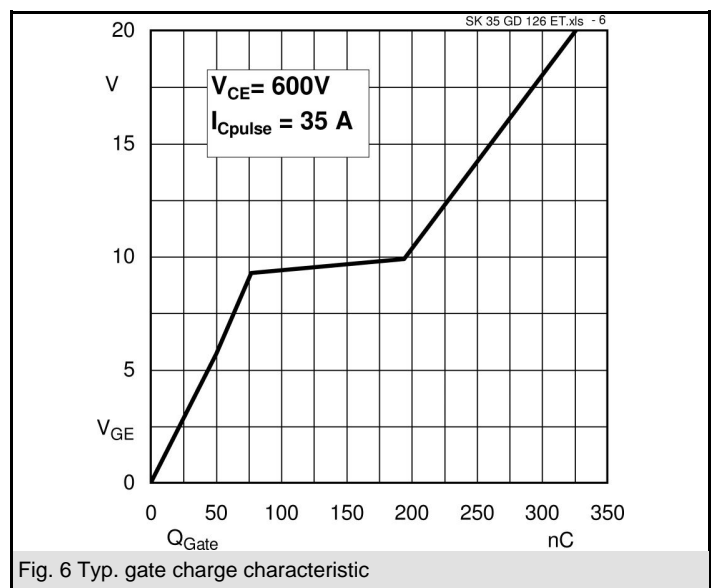
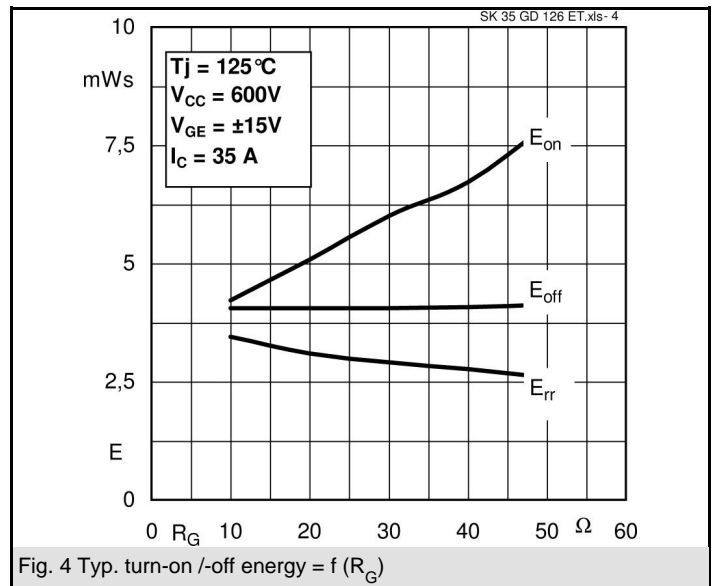
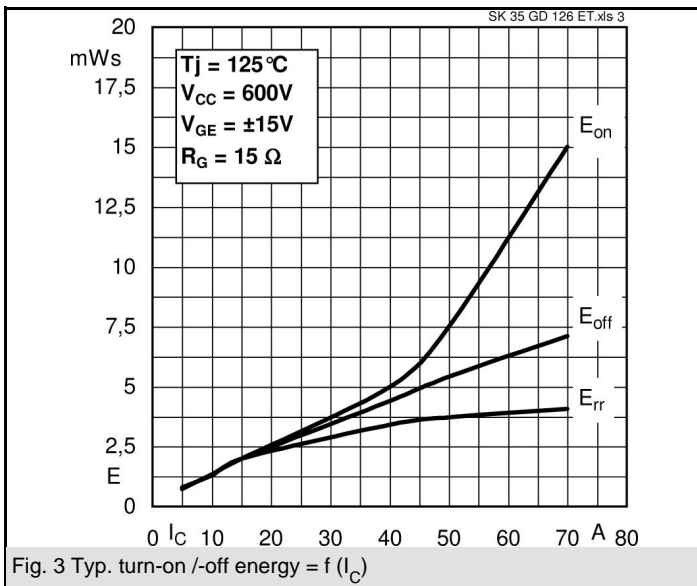
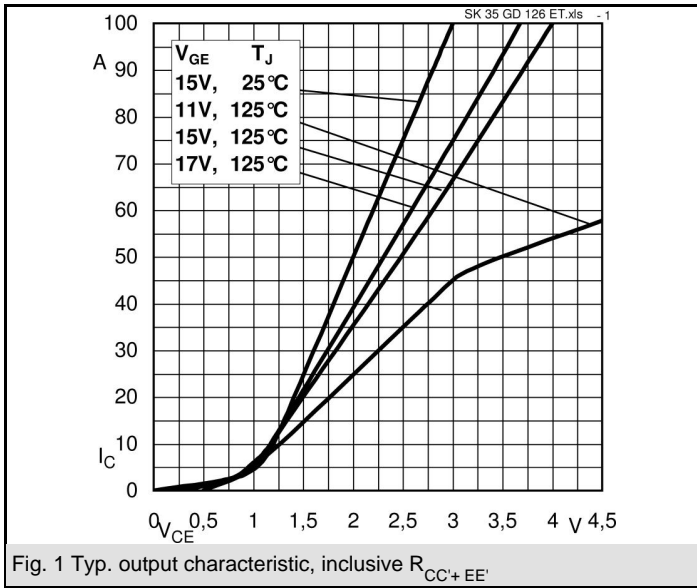

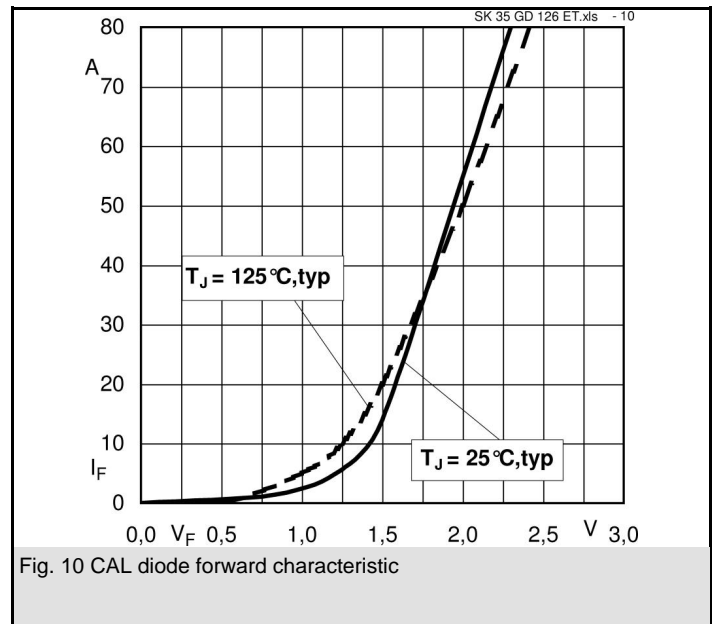
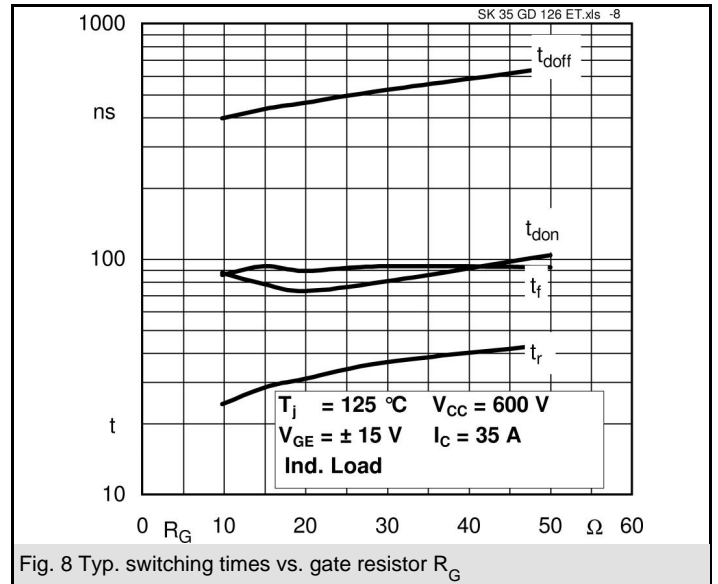
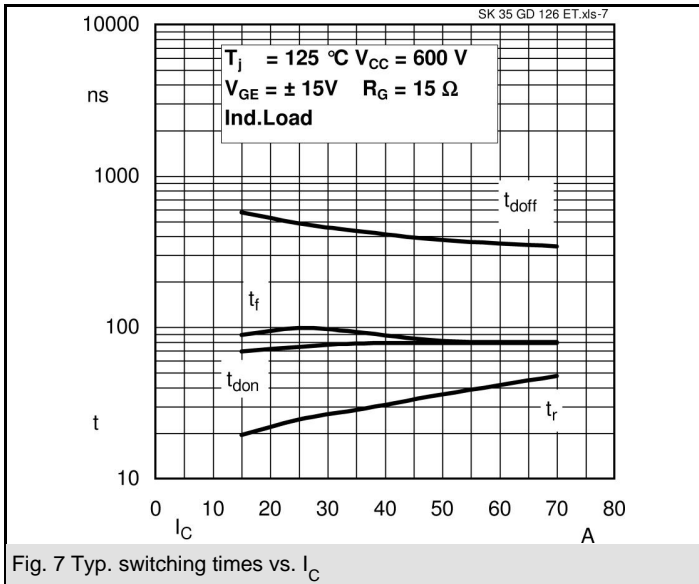

UL recognized file

no. E 63 532

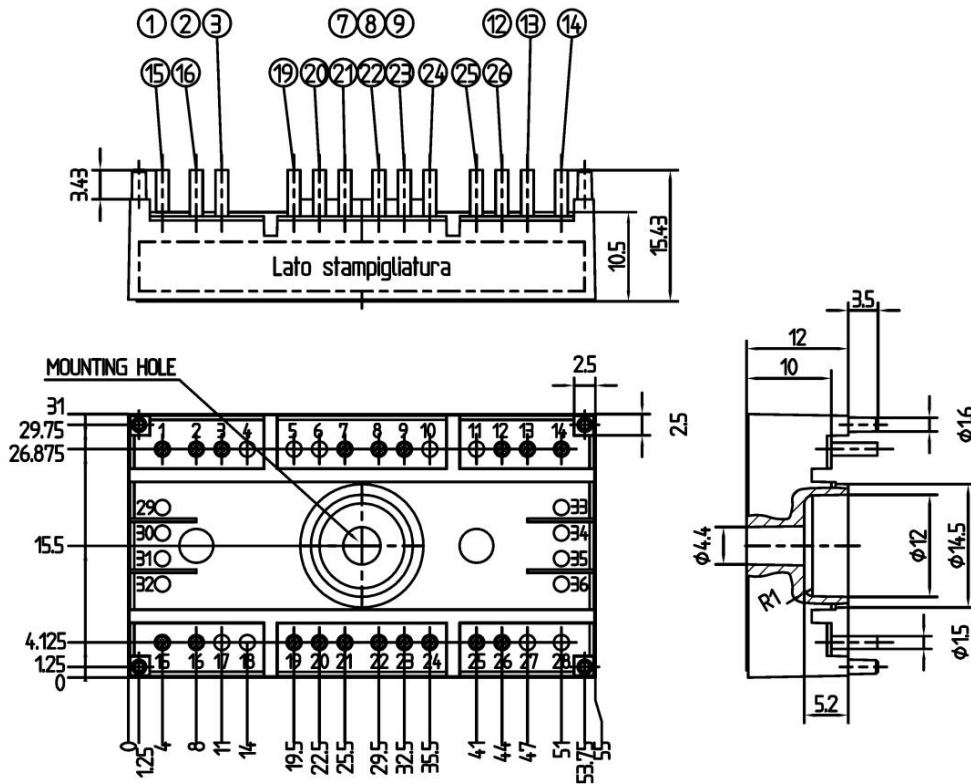

Case T52 (Suggested hole diameter, in the PCB, for solder pins and plastic mounting pins: 2mm)

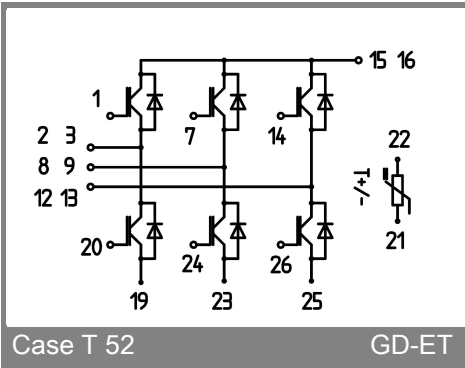

Case T 52

GD-ET