MiniSKiiP®1

3-phase bridge inverter

SKiiP 12AC12T4V1

Features

- Trench 4 IGBT's
- Robust and soft freewheeling diodes in CAL technology
- Highly reliable spring contacts for electrical connections
- UL recognised file no. E63532

Typical Applications*

- Inverter up to 12 kVA
- Typical motor power 5,5 kW

Remarks

- V_{CEsat} , V_F = chip level value
- Case temp. limited to $T_C = 125^\circ\text{C}$ max. (for baseplateless modules $T_C = T_S$)
- product rel. results valid for $T_j \leq 150$ (recomm. $T_{op} = -40 \dots +150^\circ\text{C}$)

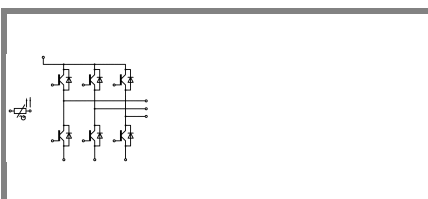
AC

Absolute Maximum Ratings		$T_C = 25^\circ\text{C}$, unless otherwise specified	
Symbol	Conditions	Values	Units
IGBT			
V_{CES}	$T_j = 25^\circ\text{C}$	1200	V
I_C	$T_j = 175^\circ\text{C}$	$T_C = 25^\circ\text{C}$	18 A
		$T_C = 70^\circ\text{C}$	18 A
I_{CRM}	$I_{CRM} = 3 \times I_{Cnom}$	45	A
V_{GES}		± 20	V
t_{psc}	$V_{CC} = 800\text{ V}; V_{GE} \leq 15\text{ V}; T_j = 150^\circ\text{C}$ $V_{CES} < 1200\text{ V}$	10	μs
Inverse Diode			
I_F	$T_j = 175^\circ\text{C}$	$T_C = 25^\circ\text{C}$	22 A
		$T_C = 70^\circ\text{C}$	18 A
I_{FRM}	$I_{CRM} = 3 \times I_{Cnom}$	45	A
I_{FSM}	$t_p = 10\text{ ms}; \text{sin.}$	$T_j = 25^\circ\text{C}$	64 A
Module			
$I_{t(RMS)}$		40	A
T_{vj}		-40...+175	$^\circ\text{C}$
T_{stg}		-40...+125	$^\circ\text{C}$
V_{isol}	AC, 1 min.	2500	V

Characteristics		$T_C = 25^\circ\text{C}$, unless otherwise specified			
Symbol	Conditions	min.	typ.	max.	Units
IGBT					
$V_{GE(th)}$	$V_{GE} = V_{CE}, I_C = 1\text{ mA}$	5	5,8	6,5	V
I_{CES}	$V_{GE} = 0\text{ V}, V_{CE} = V_{CES}$	$T_j = 25^\circ\text{C}$			0,3 mA
			$T_j = 150^\circ\text{C}$	0,8	0,9
V_{CE0}			0,7	0,8	V
r_{CE}	$V_{GE} = 15\text{ V}$	$T_j = 25^\circ\text{C}$	70	77	$\text{m}\Omega$
		$T_j = 150^\circ\text{C}$	103	110	$\text{m}\Omega$
$V_{CE(sat)}$	$I_{Cnom} = 15\text{ A}, V_{GE} = 15\text{ V}$	$T_j = 25^\circ\text{C}_{chiplev.}$	1,85	2,05	V
		$T_j = 150^\circ\text{C}_{chiplev.}$	2,25	2,45	V
C_{ies}	$V_{CE} = 25, V_{GE} = 0\text{ V}$	$f = 1\text{ MHz}$			0,9 nF
C_{oes}					0,08 nF
C_{res}					0,055 nF
Q_G	$V_{GE} = -8 \dots +15\text{ V}$			85	nC
R_{Gint}	$T_j = 25^\circ\text{C}$			0	Ω
$t_{d(on)}$	$R_{Gon} = 39\ \Omega$ $di/dt = 400\text{ A}/\mu\text{s}$	$V_{CC} = 600\text{ V}$ $I_C = 15\text{ A}$			31 ns
t_r					30 ns
E_{on}					1,65 mJ
$t_{d(off)}$	$R_{Goff} = 39\ \Omega$ $di/dt = 200\text{ A}/\mu\text{s}$	$T_j = 150^\circ\text{C}$ $V_{GE} = \pm 15\text{ V}$			315 ns
t_f					66 ns
E_{off}					1,5 mJ
$R_{th(j-s)}$	per IGBT			1,3	K/W

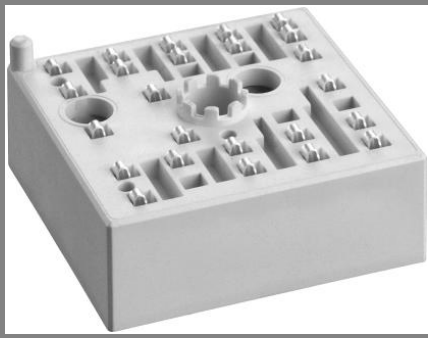
MiniSKiiP®1

3-phase bridge inverter

SKiiP 12AC12T4V1

Features

- Trench 4 IGBT's
- Robust and soft freewheeling diodes in CAL technology
- Highly reliable spring contacts for electrical connections
- UL recognised file no. E63532

Typical Applications*

- Inverter up to 12 kVA
- Typical motor power 5,5 kW

Remarks

- V_{CEsat} , V_F = chip level value
- Case temp. limited to $T_C = 125^\circ\text{C}$ max. (for baseplateless modules $T_C = T_S$)
- product rel. results valid for $T_j \leq 150$ (recomm. $T_{op} = -40 \dots +150^\circ\text{C}$)

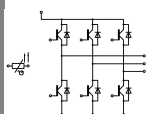

AC

Characteristics

Symbol	Conditions	min.	typ.	max.	Units	
Inverse Diode						
$V_F = V_{EC}$	$I_{Fnom} = 15 \text{ A}; V_{GE} = 0 \text{ V}$		$T_j = 25^\circ\text{C}_{chiplev.}$	2,4	2,75	V
			$T_j = 150^\circ\text{C}_{chiplev.}$	2,45	2,8	V
V_{F0}			$T_j = 25^\circ\text{C}$	1,3	1,5	V
			$T_j = 150^\circ\text{C}$	0,9	1,1	V
r_F			$T_j = 25^\circ\text{C}$	73	83	mΩ
			$T_j = 150^\circ\text{C}$	103	113	mΩ
I_{RRM}	$I_F = 15 \text{ A}$	$T_j = 150^\circ\text{C}$		12	A	
Q_{rr}	$di/dt = 500 \text{ A}/\mu\text{s}$			2	μC	
E_{rr}	$V_{GE} = \pm 15 \text{ V}$			0,79	mJ	
$R_{th(j-s)}$	per diode		1,92		K/W	
M_s	to heat sink	2		2,5	Nm	
w			35		g	
Temperature sensor						
R_{ts}	3%, $T_r = 25^\circ\text{C}$		1000		Ω	
R_{ts}	3%, $T_r = 100^\circ\text{C}$		1670		Ω	

This is an electrostatic discharge sensitive device (ESDS), international standard IEC 60747-1, Chapter IX.

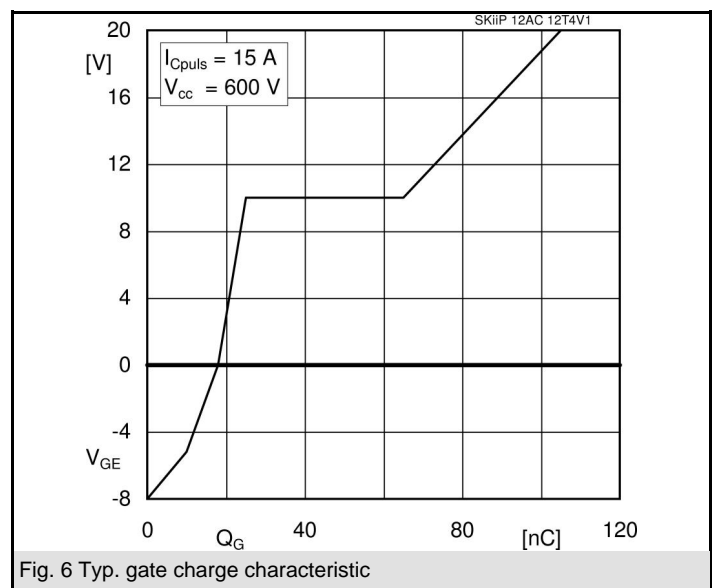
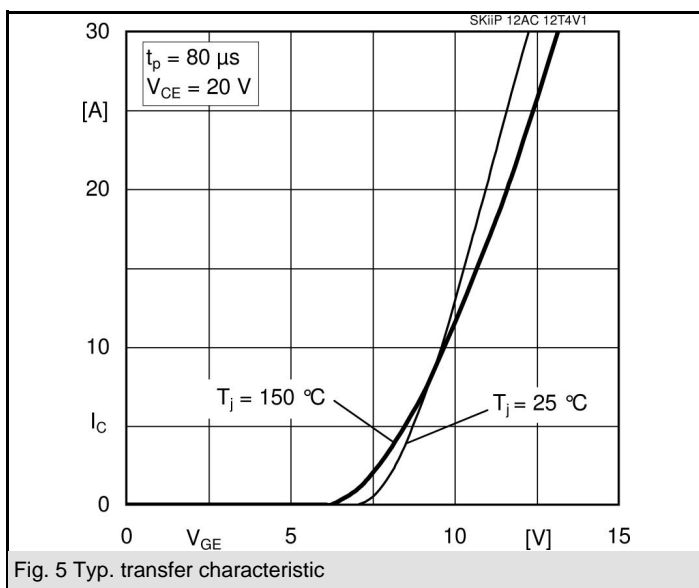
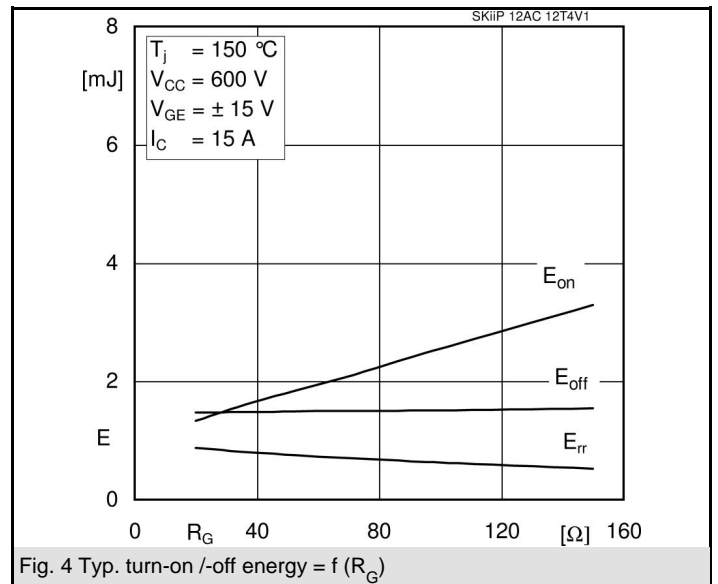
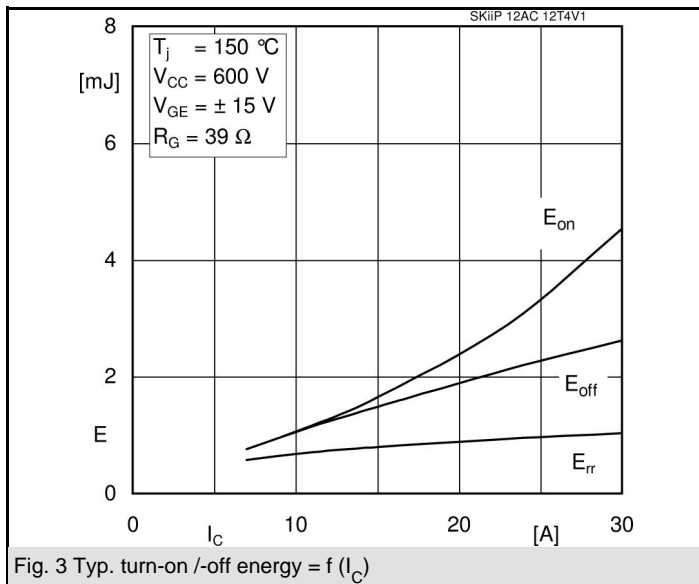
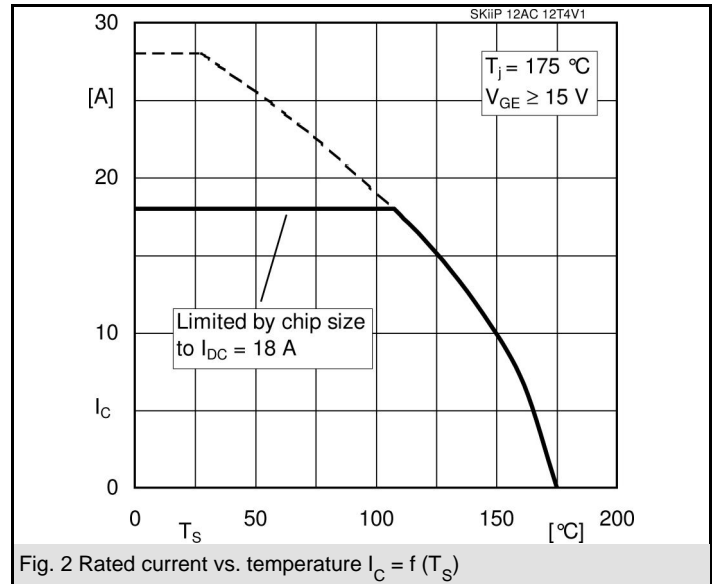
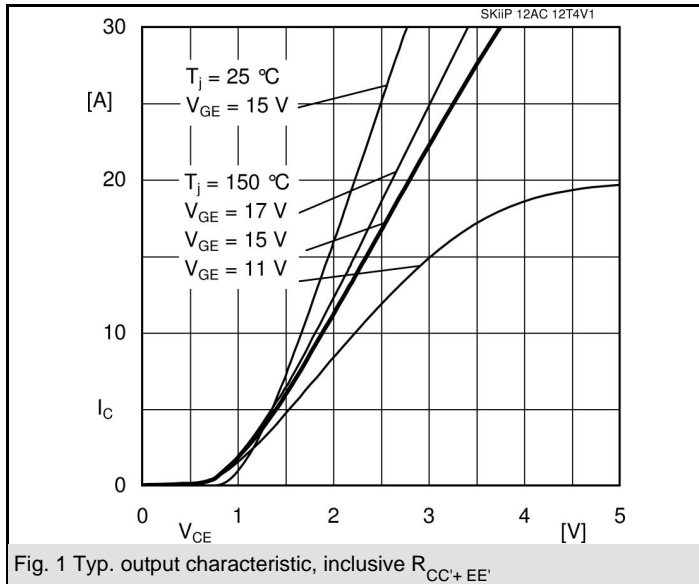
* The specifications of our components may not be considered as an assurance of component characteristics. Components have to be tested for the respective application. Adjustments may be necessary. The use of SEMIKRON products in life support appliances and systems is subject to prior specification and written approval by SEMIKRON. We therefore strongly recommend prior consultation of our personal.



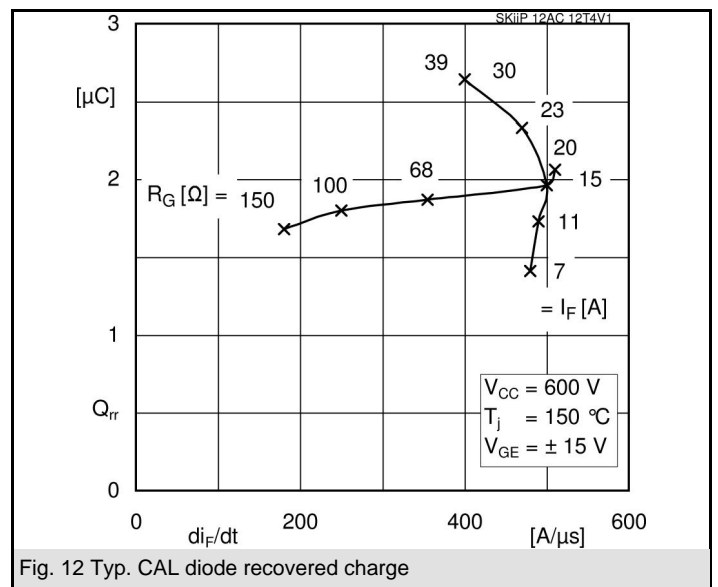
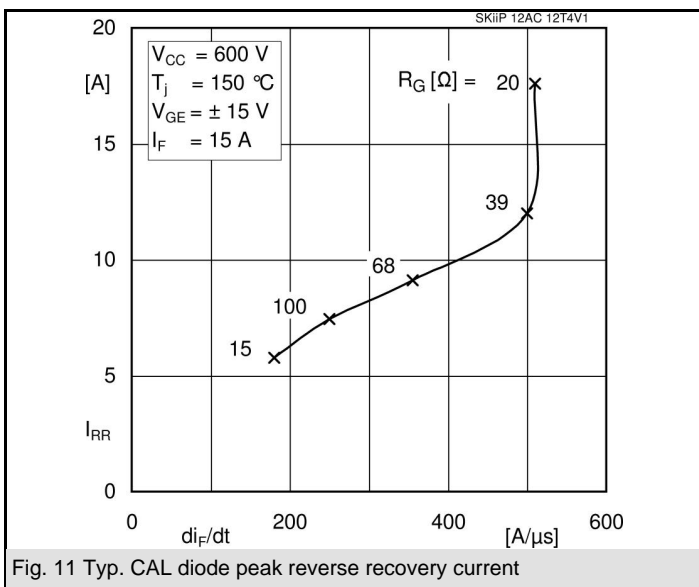
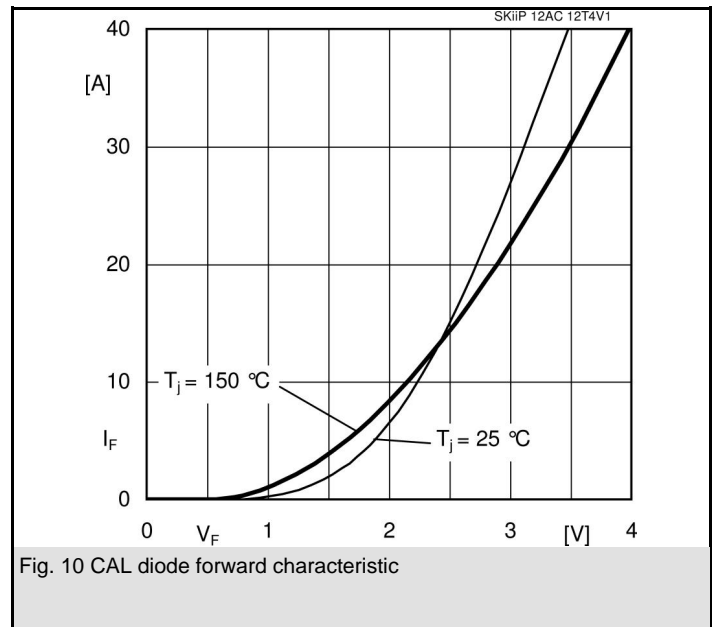
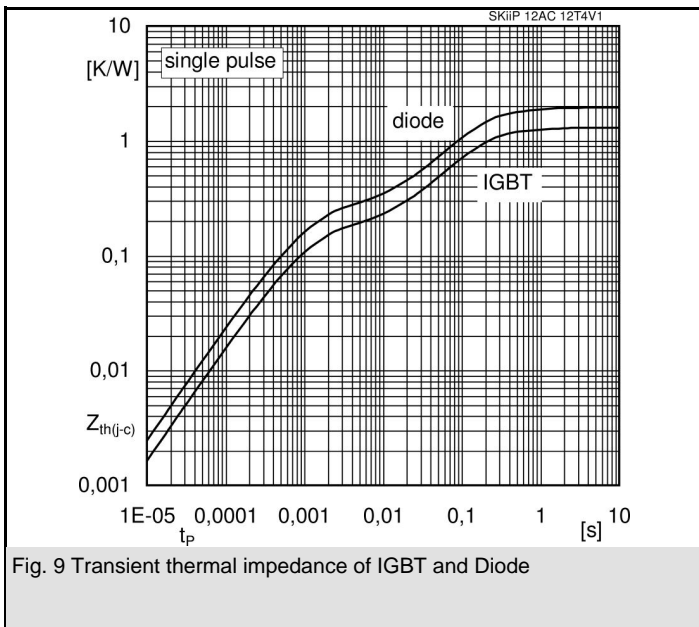
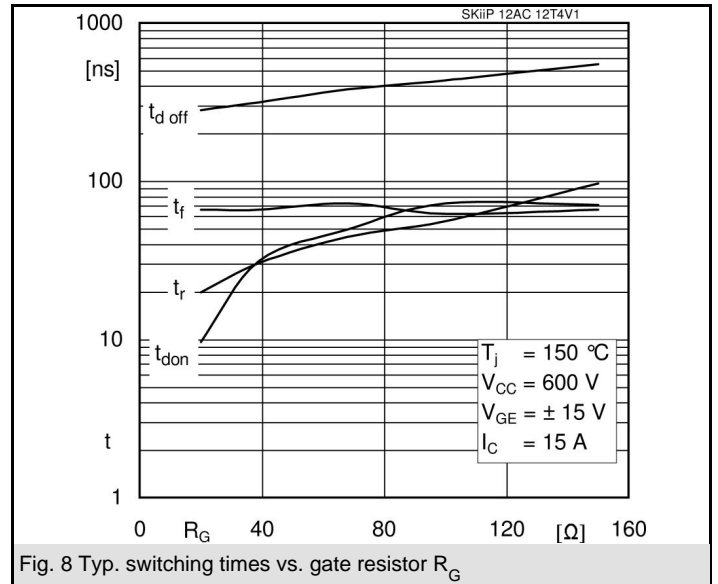
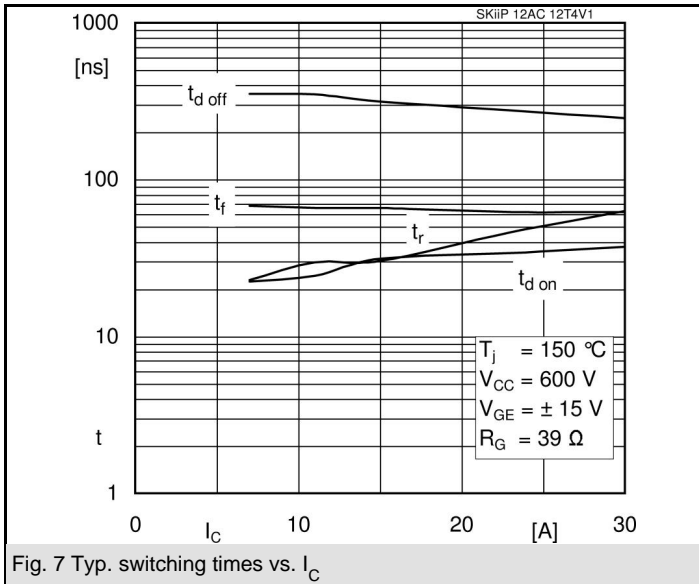

UL recognized file

PCB PCB TOP-VIEW

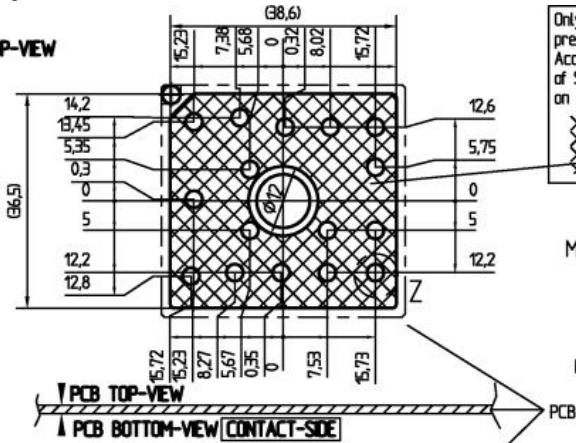

MiniSKiiP 1

no. E 63 532

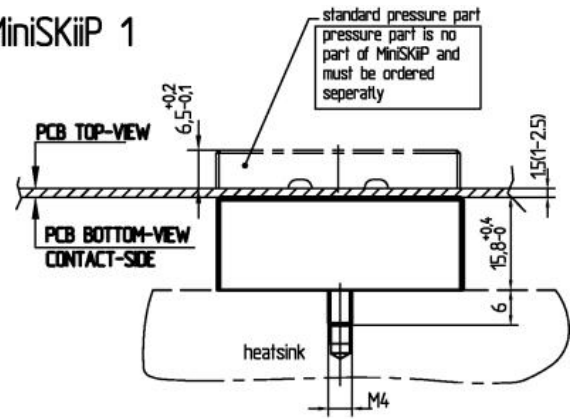

PCB BOTTOM-VIEW CONTACT-SIDE

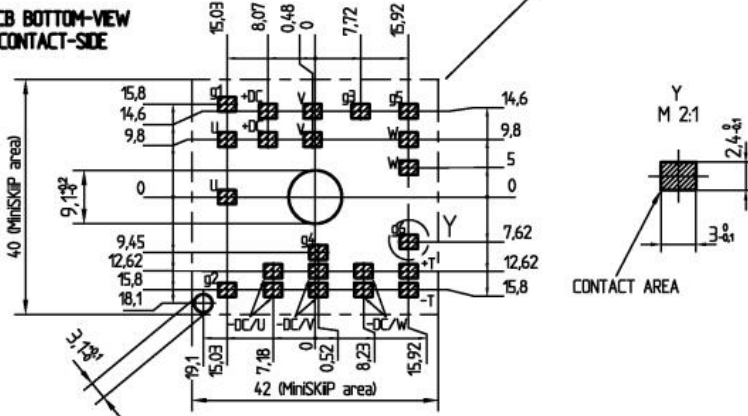

For mounting please follow the assembly instruction

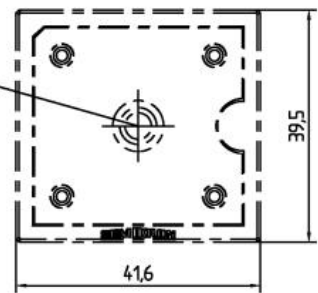

measure: mm
tolerance: ISO 2768-f

case

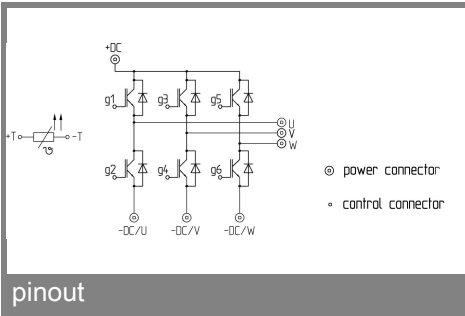

pinout